

Design Data	
Commutation	Brushed
Direction of rotation	Bi-directional
Bearing type	A: Ball - B: Sleeve

Performance data		
Rated voltage [V]	$U_N$	24
Nominal torque [Nm]	$M_N$	8.00
No-load speed [ $\text{min}^{-1}$ ]	$n_0$	75.0
Nominal power [W]	$P_N$	37.7
Nominal current [A]	$I_N$	7.0
Nominal force [kN]	$F_N$	0.00
Duty cycle	s1	

Sensor data	
Pulses	63
Output channels	1

Other data	
Gear ratio	63/1
Gear wheel material	Plastic
Suppression components	3.5 $\mu\text{H}$
Enclosure class	IP30
Weight [kg]	1.250

Remarks: d = for thread-forming screw M6 DIN ISO 965-2

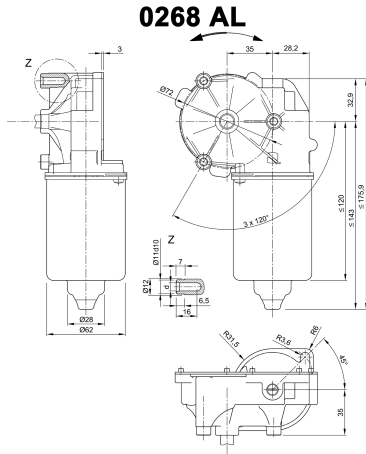

**Motor picture**



**Characteristic curves**

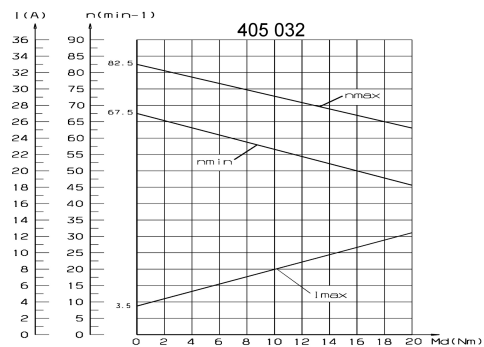

**Output shaft drawing (W), Wiring diagrams (S) and Connector layout (K)**

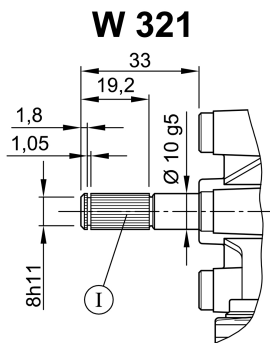

I serration (rolled): no of teeth 28, pitch circle dia 9 mm, tip circle dia 9.6 mm, root circle dia 8.26 mm space width angle 60°- go/no go gauge Frenco 33906 - [www.frenco.de](http://www.frenco.de)

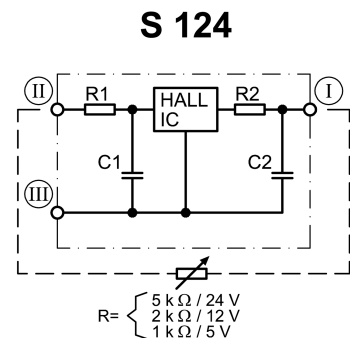
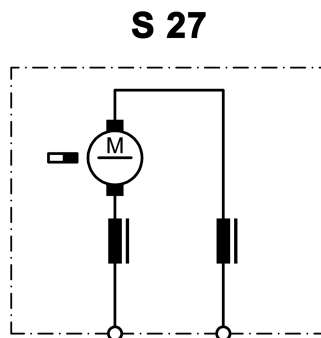

I Terminal 3, A  
 II Terminal 4, +  
 III Terminal 5, -

$$R = \begin{cases} 5 \text{ k}\Omega / 24 \text{ V} \\ 2 \text{ k}\Omega / 12 \text{ V} \\ 1 \text{ k}\Omega / 5 \text{ V} \end{cases}$$

Output shaft drawing (W), Wiring diagrams (S) and Connector layout (K)

### K 320

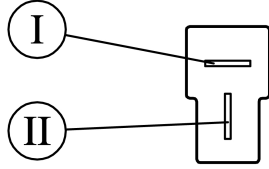

Fiat plug (DIN 46244) 6,3x0,8 mating with receptacle housing part#180907, drwg# C-180907& Receptacles for tabs, conductor cross section 0,5-1,5 sqmm (20-18AWG) part# 925603-x, drwg# 925603 [www.tycoelectronics.com](http://www.tycoelectronics.com)

### K 325

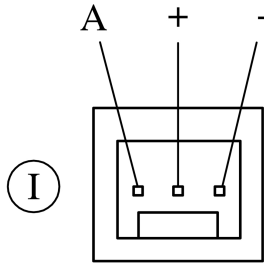

MAS-CON Solder tail MLAS 100-3435 mating with end connector CE100F-22-xx-x-x or CEP100 F-22-xx-x-x [www.itwpancon.com](http://www.itwpancon.com)

### K 312

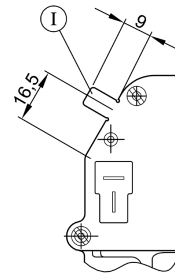

Ground connection 6.3 x 0.8 DIN 46 244, d=0,9-0,1mm, mating with receptacle for tab, conductor cross section 0,5-1,5 sqmm/20-16 AWG, part# RSB8240.158 F 6.3-1.5 [www.stocko.de](http://www.stocko.de)

## Notes

---

---

---

---

---

---

---

---

---

---

---

---

---

---

---

---

---

---

---

---

---

---

---

---

---

---

---

---

---

---